

Taal: Engels



Handleiding

B TEC spuitpistoolreiniger
BT Starter 02

MSH equipment
Appelmarkt 7
1681 PE Zwaagdijk-Oost
Tel: 0228-561100
Fax: 0228-561112
Mail: info@msh-equipment.nl

Website: www.msh-equipment.nl

Declaration of conformity according to DIN EN 45014

Manufacturer: B-TEC GmbH
Zunftweg 6-8
D-31303 Burgdorf / Ehlershausen



Herewith, we declare that the machines and marketed models described in the following conform in conception and in design to the relevant fundamental safety and health requirements of the applicable EU directives.

All of our manufactured or assembled parts conform to the listed regulations.

If you change the machine without our explicit agreement, this declaration will be herewith invalidated.

Product type: Spraying-gun cleaning-device

Type designation: **Starter 01** **Starter 02**

Serial-nr.: **Construction year : 2013**

The machines conform to the following regulations:

Maschinenrichtlinie 2006/42/EG

Explosionsschutz-Richtlinie 94/9/EG ; Registered with: PTB 0102 / R.Nr.: 05 ATEX D 116

The following harmonising standards have been used:

Safety of machinery, equipment and facilities: **CEN EN 12100-1 / CEN EN 12100-2 / CEN EN 14121-1**

Machines for surface cleaning, aqueous and combustible liquids: **CEN EN 12921-2 / 12921-3**

General rules and safety requirements for pneumatic-systems: **DIN EN ISO 4414**

Special national norms are applied:

Guidelines for facilities to clean workpieces with liquid detergents: **BGR 180**

Safety- and healthsigns at workplace: **BGV A8**

Ex declaration: Ex II 2 G c II B<T6

Responsibility for technical documents: Hans-Joachim Bödrich, Michael Bellroth

Address: Refer to manufacturer's address

Location/Date/Manufacturer's signature

.....Hannover, 01.03.2013.....

Function of the signer: Managing director

Table of contents

1. Important information	1
1.1 Explanation of the symbols.....	2
2. Technical description of the cleaner	3
2.1 Technical Information	3
2.2 Item descriptions and spare parts ordering numbers.....	5
2.3 Pneumatic plan and spare parts ordering numbers.....	7
3. Approved cleaning agents	8
4. Safety regulations	9
4.1 Instructions, rules and information of the employers' liability insurance association	9
4.2 Safety instructions.....	10
4.3 Safety regulations pertaining to the installation of B-TEC machines	11
5. Transport and installation	12
5.1 Requirements to the installation site.....	12
5.2 Installation	12
6. Operating instructions	14
6.1 Commissioning.....	14
6.2 Operational procedure	14
6.3 Adjusting facilities	16
7. Care and maintenance	17
7.1 Maintenance of the machine.....	17
7.2 Disposal	17
8. Safety inspection checklist	18

1. Important information



We thank you for your trust you gave to us by buying the spraying-gun cleaning-device "Starter". At the rating plate at your cleaner you will find the exact name and serial-number of your cleaner for an uncomplicated service and shipment of spare parts.

The B-TEC cleaner has been built under highest quality standards for high reliability. Because of certain procedures there are places and parts that can't be protected without compromising the usability and function. Therefore we ask you to read this document carefully before using the cleaner to reach maximum life and reliable operation.



Read this document carefully before commissioning and keep it for future reference!

On page 18 of this instruction book there is a form for documenting safety inspections at regular intervals. The form has only to be filled out by specialist technicians (persons with sufficient knowledge and experience or manufacture's mechanics) or experts (e.g. engineers or Technical Control Board experts).



Safety inspections have to be conducted before operation and at least once every year!

The B-TEC devices and machines are only allowed to be used for the purpose explicitly described below. Any other use is in contrast with the regulations. The manufacturer cannot be held liable for damages resulting from such non-regulations use.



The B-TEC devices and machines are only to be used for the purpose explicitly described below!

These devices and machines are allowed to be used for cleaning varnish and spray paint guns as well as paint soiled parts and hand tools using solvents (A I, A II, A III) or non-combustible, aqueous cleaners for water-based varnishes. Exception: share of Aceton > 65 %.

The cleaners are not allowed to be used in continuous operation as for instance in serial production. Improper use of the washers can endanger the health of the operator and of others and cause damage to the cleaner itself or to other materials and assets.



Improper use of the cleaners can endanger the health of the operator!

1.1 Explanation of the symbols

Attention!



You will find this symbol whenever attention is drawn to situations in which danger to life can arise due to or during incorrect or improper operation. Pay special attention to these symbols and act carefully.

Notice!



You will find this symbol in the operating manual whenever your attention shall be drawn to correct work procedures, economic ways of operation or when the machines can be damaged by incorrect operation.

2. Technical description of the cleaner

Starter 01

The universal washer "Starter 01" is produced for automatically cleaning spray paint guns. The automatic wash cycle is activated by a timer. In addition, there is a brush and a fresh solvent jet in the wash enclosure for cleaning objects or spray guns manually.

Starter 02

The "Starter 02" is a washer for manual cleaning of objects and spray paint guns with a brush and a fresh solvent jet.

All models have a strong exhaust system that switches on and off automatically as soon as the hatch is opened or closed. All models are operated exclusively by pneumatic parts.

2.1 Technical Information

Compressed-air connection

Operating pressure: max. 6 bar

Acoustic emission¹

Closed machine: 74 dB(A)

Opened machine: 76 dB(A)

Exhaust air flow rate at operating Pressure 6 bar 380 m³/h

Containers

Size 30 Liter

Quantity 2

¹ Measurement at ear level - Tolerance: 0,5% measurement method - 1,0 dB(A) analyzer

External dimensions

Width: 670 mm
 Depth: 500 mm
 Height: 370 mm (Cover plate closed)
 Height: 770 mm (Cover plate opened)

Cleaning-room

Width: 490 mm
 Depth: 410 mm
 Height: 295 mm

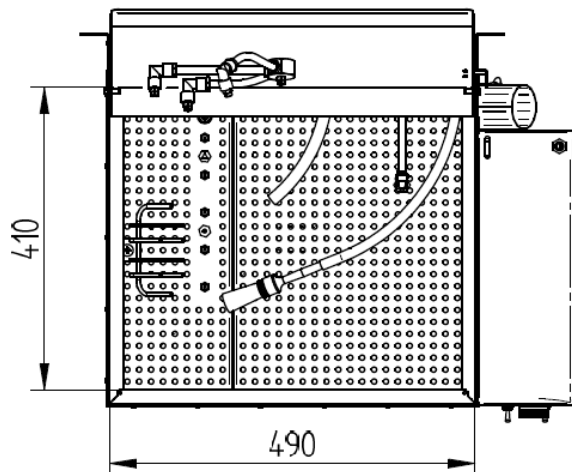
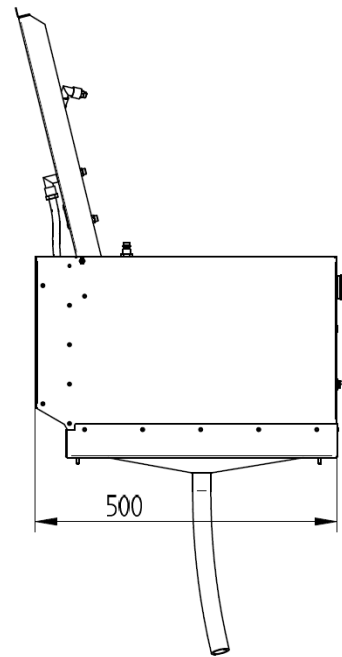
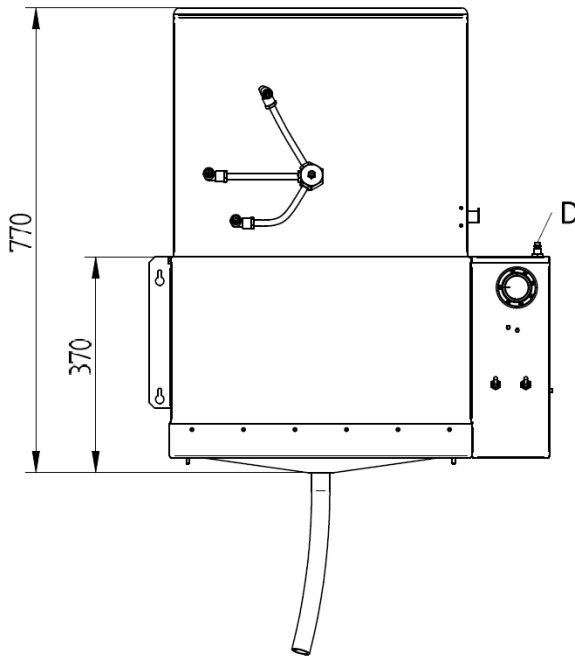

- Technical changes and errors reserved. All pictures similar -

2.2 Item descriptions and spare parts ordering numbers

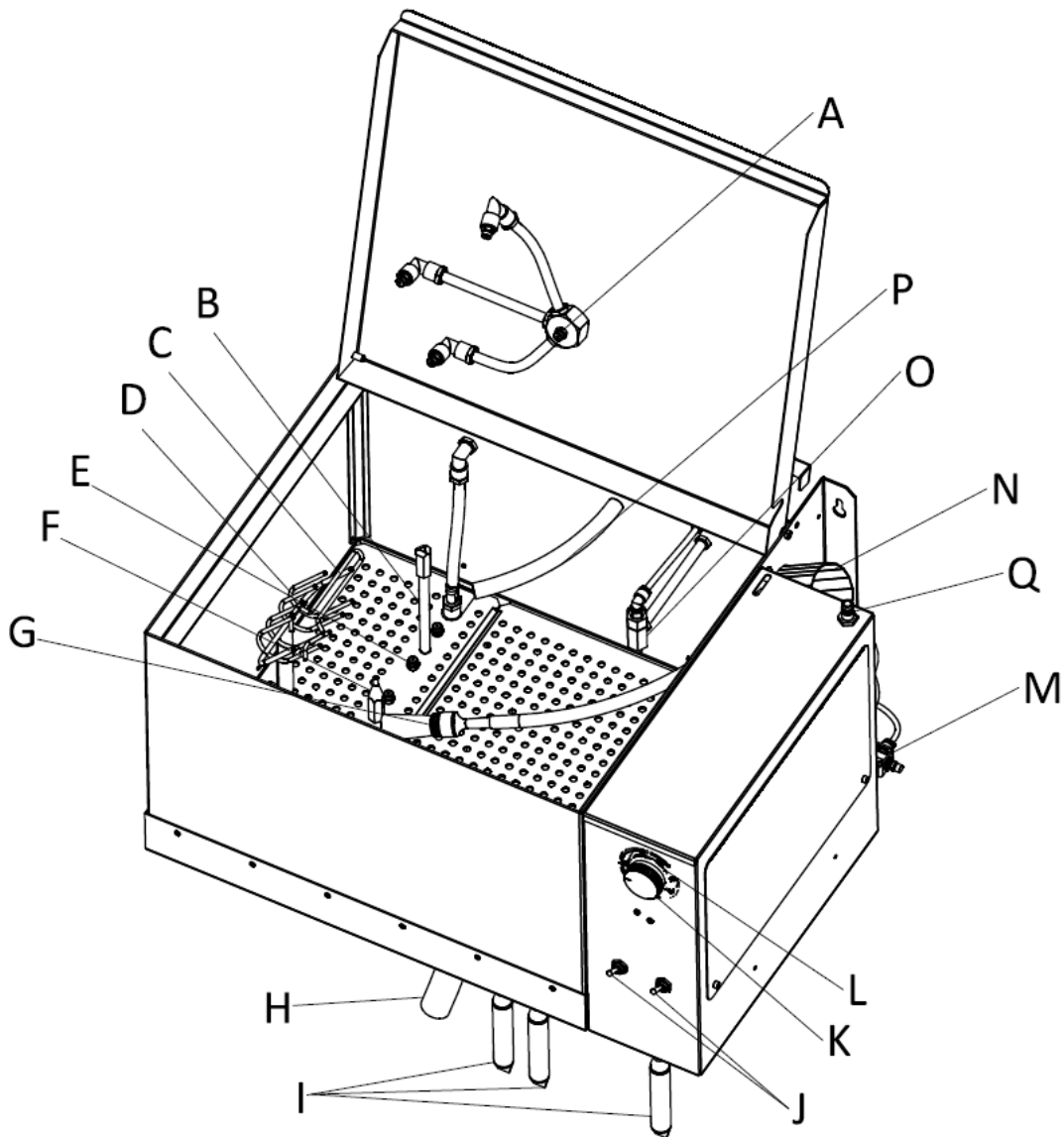

A	- Blast connection	010.050.015.050.ST.kpl
B	- Cup holder	10.50.15.15
C	- Trigger clamp	35.15.05
D	- Lid holder	35.20
E	- Injector	25.05.10
F	- Middle-jet	025.005.005.005 St.
G	- Brush with hose	10.50.15.10
H	- Drain hose	30.25.20 St.
I	- Intake-strainer	95.05
J	- Dip-switch fresh solvent jet & brush	05.40.05.05
K	- Timer knob	55.05
L	- Timer scale	55.15
M	- Throttle valve	05.10.25.10
N	- Draw-jet	10.50.05.30 St.
O	- Fresh solvent jet	10.50.15.25 St.
P	- Compressed air hose for flushing spray gun	30.25.15 St.

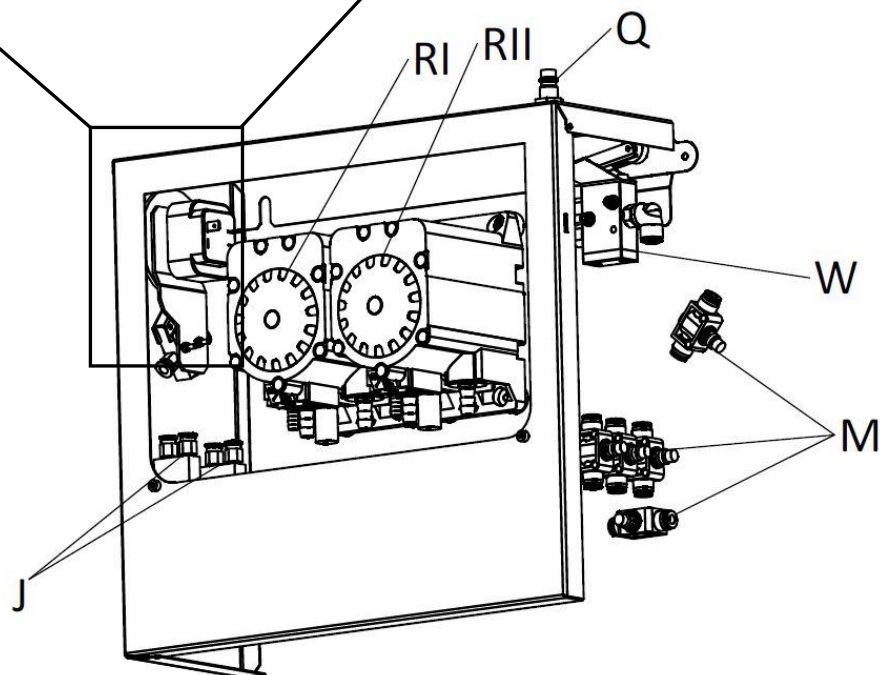
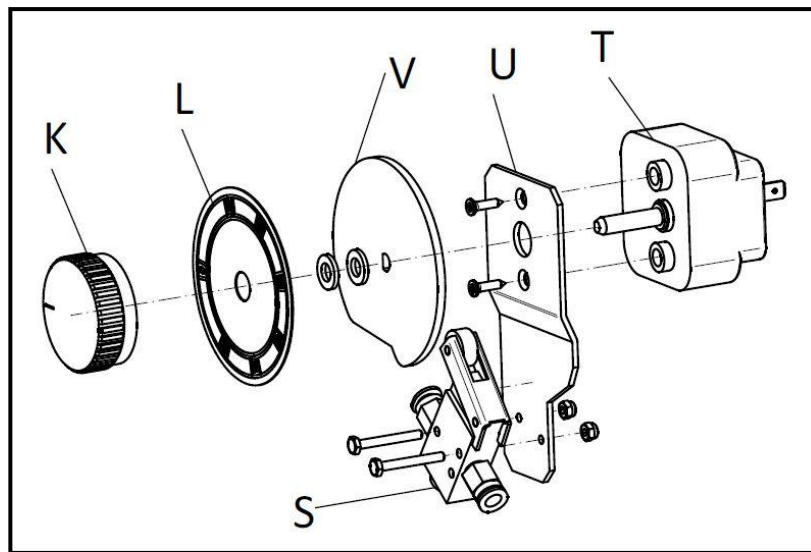

Q	- Connecting plug compressed air	50.20.05
RI	- Pump brush	020.005.020
RII	- Pump jet automatic	020.005.020
S	- Role valve	05.05.05.05
T	- Short-timer / clock unit	55.10
U	- Bracket	035.005.005.005
V	- switch-plate	035.005.005.010
W	- Role valve with connections	10.50.05.20.10

2.3 Pneumatic plan and spare parts ordering numbers

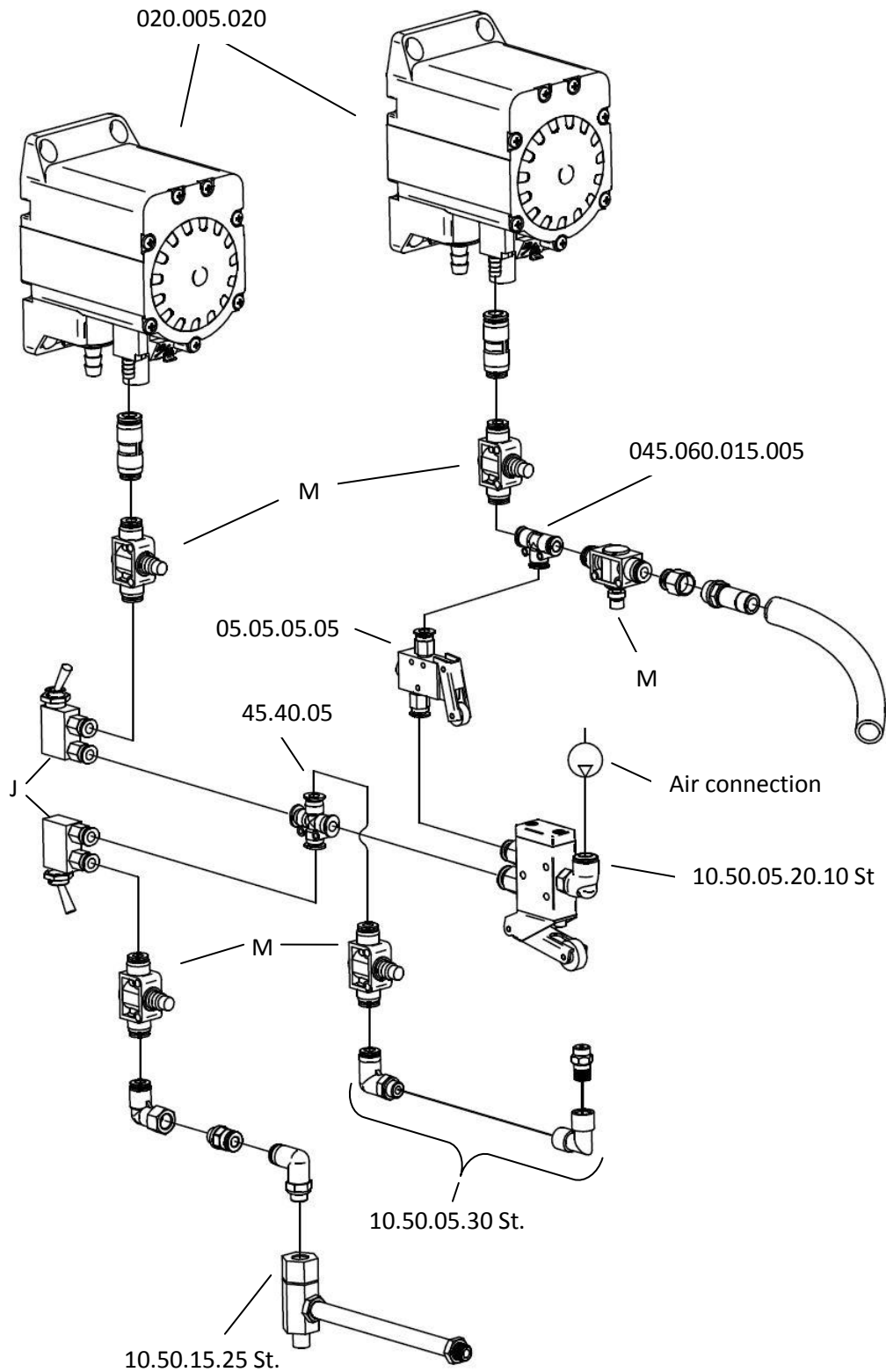

- | | | |
|---|------------------|-------------|
| M | - Throttle valve | 05.10.25.10 |
| J | - Dip-switch | 05.40.05.05 |

3. Approved cleaning agents

- Highly flammable liquids, hazard symbol „F“ / R 11 flashpoint < 21°C
GHS/CLP H 225 flashpoint < 23°C, boiling point > 35°C
- Flammable liquids, hazard symbol - / R 10, flashpoint 21 – 55°C
GHS/CLP H 226 flashpoint 23 – 60°C
- Non-flammable aqueous cleaning agents (neutral or slightly alkaline pH value for water-soluble paints and dyes, such as demineralized water).
- The machines Starter 01 and 02 are classified as machine category 2, group II, machine type explosion group II B and can be used in zone 1.
See also machine rating plate: **Ex II 2 G c II B < T6**



Acids are not permitted. Paint strippers or other additives (e.g. brake cleaners etc.) may must not be used in the washing unit.



Ask the supplier of your cleaning device for a material safety data sheet. This provides information about the cleaning medium you are using.



Never alternately use solvents and cleaning agents for water-based paints. Follow the cleaner manufacturer's instructions. Alternating the two types of agents can cause gas buildup and the risk of an explosion.



If you plan on changing from solvent to water-based paint remover (or the other way round), the spray gun washing unit has to be completely cleaned of all paint, water, and solvent residues.



Recommendation to reduce solvent consumption:
If the unit shall be connected to a continuously running exhaust when using solvent, we recommend the pneumatic exhaust damper to reduce solvent consumption.
See B-TEC, catalog no.: 065.015.030.005 / ATEX version.

4. Safety regulations

The B-TEC GmbH machines are operationally safe and are constructed according to the state of the art. Due to the nature of the processes there are processes and parts that cannot be protected without impairing operability and functionality. Improper use of the gun-cleaner can endanger the health of operator and of other and cause damage to the cleaner itself or to other materials and assets. B-TEC GmbH is not liable for any damages resulting from improper or incorrect use.



The manufacturer is not liable for damages caused by changes of the cleaner that have not been specifically authorized by the manufacturer. The removal or alteration of safety devices immediately voids the warranty and is an infringement of European safety standards.



Read and follow this Instruction manual and the safety instructions carefully before commissioning!

4.1 Instructions, rules and information of the employers' liability insurance association



The following occupational safety regulations (BGV), rules (BGR), and information (BGI) have to be followed while using spray guns and part cleaning systems:

- BGV A1** "Principles and prevention", general rules
- BGV A8** "Safety and health protection warnings at the workplace"
- BGR 121** "Safety rules for air pollution control systems for the workplace"
- BGI 578** "Security by operating instructions"
- BGI 5127** " Avoidance of ignition from electrostatic charges"
- BGR 180** " Guidelines for facilities for cleaning parts with solvents"
- BGR 189** " Use of protective clothing"
- BGR 192** "Use of eye and face protection"
- BGR 195** "Use of protective gloves"
- BetrSichV** " Ordinance on Industrial Safety"

The source documents (with exception of the " Ordinance on Industrial Safety") can be obtained from: Carl Heymann Verlag KG, Luxemburger Str. 449, D-50939 Köln, Germany.

4.2 Safety instructions

- **The following persons are not allowed to operate the cleaner:**
 - Women who are pregnant or breastfeeding
 - Persons with chronic breathing problems and allergic illnesses
 - Children below 16 years may be employed only under the supervision of a technical expert
- The exhaust system has to be connected continuous whenever operating the machine to avoid the risk of fire, explosions and health impairment.
- Provisions have to be made for protective clothing depending on how the machine is operated (gloves, eye protection, airway protection, whole body protection).



- Hands have to be washed thoroughly before eating or drinking
→ Danger of poisoning!
- Keep the operating manual available near to the machine.
- Observe the respective information sheets of the trade co-operative association and the safety sheets when working with solvents.
- Make use of local safety and accident prevention regulations always during the operation of the machine. These have to be observed and adhered to.
- If water is used as a cleaning agent with or without additives, must not be fed into the sewer system. At this point obtain information from your local water authorities.
- Solvent spill has to be handled according to water protection laws and regulations.
- Adherence to maximal workplace concentrations according to the DIN-safety regulation sheets have to be documented.
- The maximal concentration limits according to „TA-Luft“ have to be observed
- Only use approved solvents or cleaning agents according to page 8.
- A sufficient conductivity of the clothing (especially shoes) should be respected.



A good grounding is essential!

4.3 Safety regulations pertaining to the installation of B-TEC machines

The risk zoning around the cleaning machine and the possible creation of an explosion protection document is, in accordance with legal requirements, the operator's obligation, because this division is inter alia depending on the solvents used and various conditions such as the ventilation. However, at this point the operator should be supported with general advice to comply with the obligation. Helpful advice can also be read at BGR 104, BGR 180 and DIN EN 12921-1 and -3.

For example, in many cases the classification of the zones looks like this:

Zone 0 => The interior of the machine

Zone 2 => In periphery of 1,0 – 1,5 m

Identify the different zones with appropriate warning and prohibition signs. Marks at the floor can be helpful. In the area surrounding the unit, open flames and other ignition sources (e.g. welding or grinding equipment places) are not allowed. Similarly, smoking is prohibited. Temporary work with ignition must be approved in writing and appropriate additional safety precautions must be adhered to (remove all combustible materials, classification of a fire station, ...).



5. Transport and installation

- The machine is delivered in carton.
- Take the machine out of the carton and bring it to the installation site.



5.1 Requirements to the installation site

- The gun cleaner is build for wall mounting. Optional with a B-TEC stand.
- Horizontal industrial floor, if the machine shall not be wall mounted. You also can take the B-TEC stand which has the art.-number: 65.40.20
- Dry and frost-free.
- Very well ventilated, force-ventilated, both supply and exhaust.
- Follow the safety instructions about the site.
- Follow the safety instructions according to the zone designations (chapter 4.3).
- Maintain the ambient temperatures (5° - 35°C / 41°F - 95°F) and do not expose the machine into direct sunlight, as this carries a risk of overheating.
- Horizontal, conductive industrial floor (max. discharge resistance 10⁸ Ohm).



Attention to the official prescription for the floor, otherwise take the B-TEC collecting basin for containers Art.-Nr.: 65.15.55.

5.2 Installation

Wall mounted

Hole pattern as shown in the adjacent picture. (Please take water balance !!). Depending on wall condition, please use the adequate dowel min. 6 mm. Please use screws min. 5mm. Bring the screws in the dowel so that the screw head nearly 10 mm looks out of the wall. Mount the gun cleaner on the wall and tighten up the screws. While tighten up the screws, observe that the gun cleaner does not go out of the square and that the door can be closed easily.

Assemble drain hose

Take the black drain hose (Ø23 mm) out of the machine and put on the underside of the paint gun cleaner, as shown in the picture. Fix it with the enclosed hose clamp.

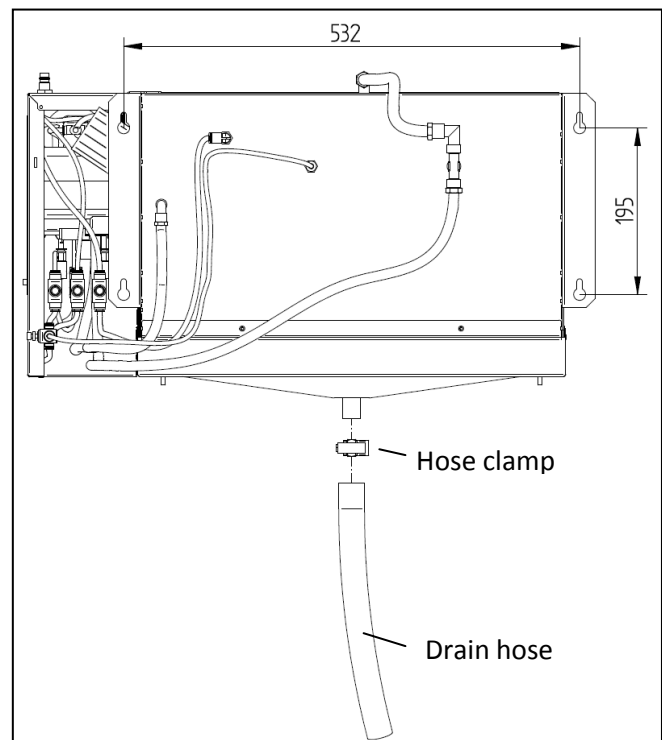



Exhaust

The waste air hose must lead outside. One has to ensure that the fumes are not led into areas where people are likely to be. The waste air has to be exhausted safely. This means that it has not to be fed into chimneys serving furnaces or fireplaces and not into exhaust channels of spraying and drying cabinets

Attention! Only use original B-TEC waste air hoses. Risk of fire if other hoses are used.

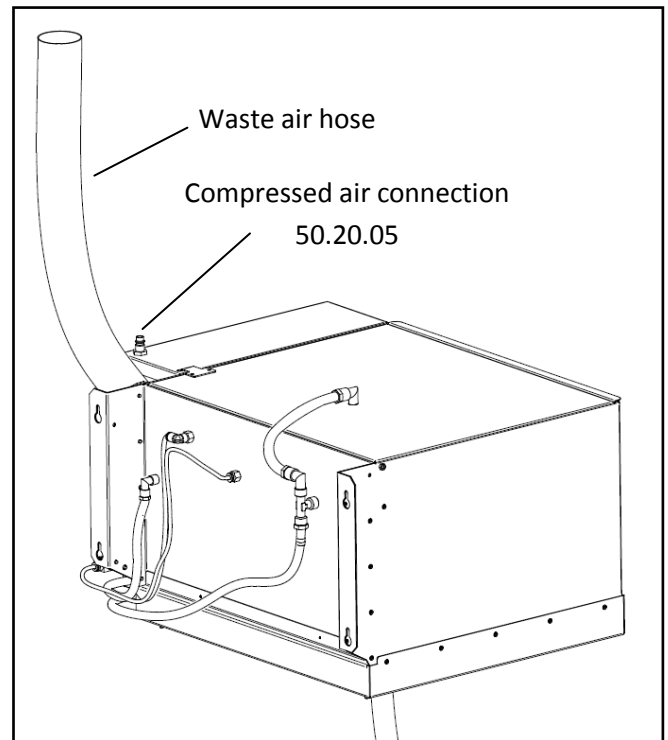

Compressed air connection

One compressed air connection has to be provided by the plant, depending on the machine:



Operating pressure max : 600 kPa (6 bar ; 87 psi)
Operating pressure min. : 500 kPa (5 bar ; 73 psi)



A pressure-regulating valve has to be used if the compressed air connections do not have the required operating pressures. **Use only dry and oil-free air!!**



Grounding: Device has a grounding cable!

- In the proximity of the pumps there is a grounding cable, which has to be grounded safely by a qualified person (e.g. electricians).
- **Customer-provided solvent tanks must be grounded separately!**

After proper installation and connection to the compressed air supply, the cleaning unit can be commissioned.



Unnecessary dry running of the membrane pumps should be avoided.



Do not open the door when the automatic wash cycle is running.
If necessary, turn the timer to "0".

6. Operating instructions

Please follow the set-up sequence exactly!!

Transport the washer to the installation site as described in chapter 4.3 „Safety regulations pertaining to the installation of B-TEC machines“, connect compressed air supply (**maximum 6 bar / 87 p.s.i.**) and attach the waste air hose.

The safety regulations in section 4 have to be read before and followed during the installation!

The following solvent drums are required:

Example: 1 x 30 litres drum filled with 20 litres and 1 x 30 litres drum filled with 10 litres. If mounted on the wall, one maybe has to use smaller drums suitable for the height of the cleaner.

6.1 Commissioning

Insert the black drain hose (Ø23 mm) and the grey intake hose (Starter-01 two grey hoses) into the 30 litres drum that is used for waste solvent. (Circuit solvent.) Insert the transparent intake hose into the 30 litre drum that is used for fresh solvent.

6.2 Operational procedure

Working with the manual side of the Model Starter-01 + 02

Open door. The exhaust starts automatically. Activate the pump of the brush with the toggle switch labelled „**Brush**“. Circulating solvent flows out of the brush. The output can be adjusted with a pressure reducing regulator that is located in front of the pump. Activate the pump of the spray jet with the **toggle switch labelled „fresh Jet“**. Fresh solvent flows out of the spray jet (30 litre drum).

When the manual cleaning area is not longer in use, switch it off and close the door. The exhaust stops automatically.



Operating the automatic washer section (Starter-01)

Open the hinged door. The exhaust system starts automatically. Then install the gun as described below:

1. Remove the lid of spray gun and place it in the lid holder. Make certain that the paint-soiled inner surface faces downwards → towards the interior of the washer.
2. The paint cup has to be removed. The strainer has to be removed from the spray gun and placed on a peg of the lid holder. After that, the spray gun has to be placed upside-down on the middle jet.
3. The paint cup has to be placed upside-down on the jet in front of the middle jet



4. The spray gun trigger is pulled back with the trigger clamp located in the washing chamber. This ensures that solvent flows through the paint channel of the spray gun. In addition, it is necessary to ensure that the set screw is "opened"-position so that the air flow is possible.



5. Connect black compressed air hose to the connection on the spray gun. This ensures that air is forced into the air channels of the spray gun during the cleaning process and that solvent and paint residues are prevented from entering.

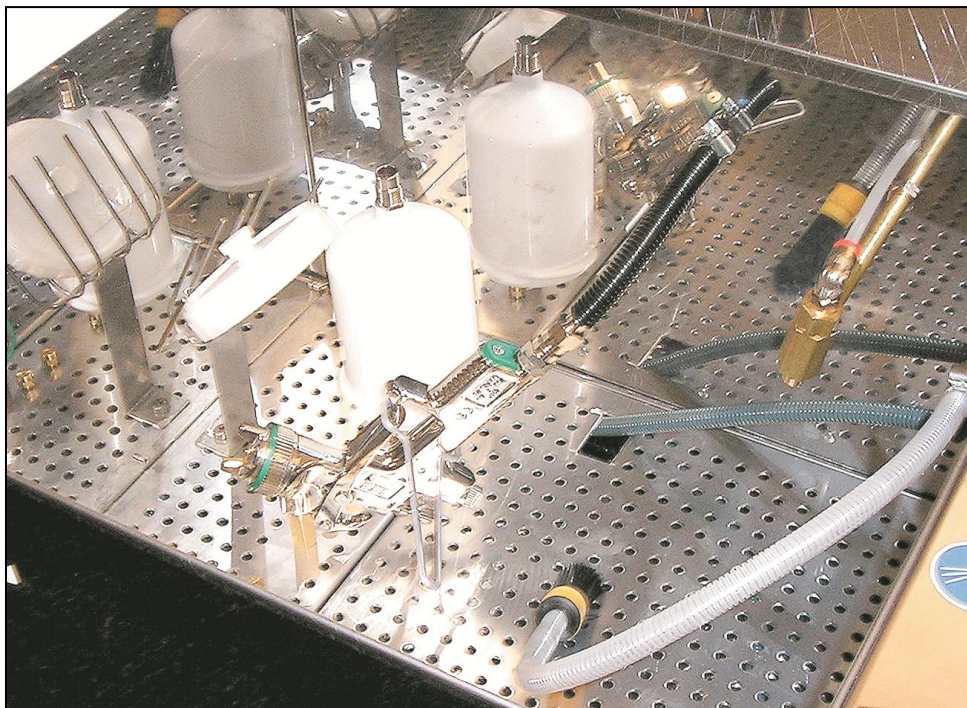



6. Close the hinged door from the gun-cleaner. **Do not allow the doors or hatches on the machine to fall shut. All machine doors and hatches must be operated with appropriate care and caution by the user.**
7. Set timer for 1-3 minutes. The main cleaning cycle is activated. Solvent is drawn from the 30 litres drum and circulated. The timer can be reset to zero by hand. When the set time is over, open the hinged door slowly and check the cleaning results.
8. Since the solvent is circulated when the timer is used, it will be heavily contaminated after a certain period. If a paint film remains on the spray gun after the main cleaning cycle, the gun has to be cleaned manually using the fresh solvent jet.
9. The spray gun is clean. Reassemble and bring it back into production.



Clean spray gun immediately after each use.



Before placing the spray gun in the washer, remove lid from the paint cup and empty remaining paint into a collection container. The more thoroughly the cup is emptied, the longer the solvent can be used in the washer.

Following these steps ensures optimal cleaning results.

6.3 Adjusting facilities

On the right back of the gun cleaner you will find valves to adjust the different functions of the gun cleaner:

Valve blue : Fresh solvent jet

Valve green : Brush

Valve red : Compressed air for flushing the spray gun while washing automatically.

7. Care and maintenance



The machine has to be disconnected from the compressed air supply before any repair work!

7.1 Maintenance of the machine

- We recommend cleaning the stainless steel filter on the intake hose regularly (at least every time the cleaner is changed.) → if the filter is defective, it must be replaced immediately. Defective filters either have heavy paint buildup, causing clogging of the filter surface, or, the filter has a breach that allows contaminated solvent to be drawn in by the pump, which can damage the pump or clog the washing nozzle.
- Clean the perforated stainless steel grille and the interior walls of the machine regularly. Clean any residue out of the drain pan, in order to ensure reliable drainage of the cleaning agent and solvent and to ensure that there is permanent sufficient flow capacity in the drain.
- When the machines will not operated for a longer period of time (for example during vacations) a clear rinse should be used after the final cleaning cycle so that the jets will not be clogged with heavily contaminated solvent.
- The operating permission will expire, if other than original B-TEC replacement parts are used.

Customer service: Contact your dealer, or directly:

B-TEC GmbH
Zunftweg 6-8
D-31303 Burgdorf / Ehlershausen
Tel.: ++49(0)5085-97100-0
Fax: ++49(0)5085-97100-30
Email.: b-tec@t-online.de
www.btecsystems.de

7.2 Disposal



- If the machine shall be disposed of, please contact B-TEC or your dealer and request an appropriate quotation or the requirements for proper disposal.
- The machine must not be disposed of as standard household waste. Depending on the level of contamination, it has to be handled as hazardous waste. Consult your local authorities as needed.

8. Safety inspection checklist

Please make copies before filling out first time!



Safety inspections must be conducted at least once every year!

<u>Item checked</u>	<u>OK</u>	<u>Missing or faulty</u>	<u>Rechecked</u>
			
1. Operating instructions	<input type="checkbox"/>	<input type="checkbox"/>	<input type="checkbox"/>
2. Model design label	<input type="checkbox"/>	<input type="checkbox"/>	<input type="checkbox"/>
3. Warnschilder	<input type="checkbox"/>	<input type="checkbox"/>	<input type="checkbox"/>
4. Condition of fluid hoses*	<input type="checkbox"/>	<input type="checkbox"/>	<input type="checkbox"/>
5. Condition of compressed air hoses*	<input type="checkbox"/>	<input type="checkbox"/>	<input type="checkbox"/>
6. Clean intake filters	<input type="checkbox"/>	<input type="checkbox"/>	<input type="checkbox"/>
7. Check washer cabinet for leaks	<input type="checkbox"/>	<input type="checkbox"/>	<input type="checkbox"/>
8. Functiontest of all control elements	<input type="checkbox"/>	<input type="checkbox"/>	<input type="checkbox"/>
9. Grounding of the gun cleaner	<input type="checkbox"/>	<input type="checkbox"/>	<input type="checkbox"/>
10. Check of the exhaust	<input type="checkbox"/>	<input type="checkbox"/>	<input type="checkbox"/>



* Check for brittleness etc.

Expert technician

Date of the safety check

Name: _____
 Address: _____

Result of the safety inspection

-  No faults, can be operated without restrictions.
-  Restricted operation, faults to be repaired by _____.
-  Operation not allowed, Re-inspection necessary.

Signed by expert technician

Signed by operator

After correction faults

Signed by expert technician

Signed by operator

B-TEC Ersatzteil-Bestellnummern

Typ: Starter

Seite 1

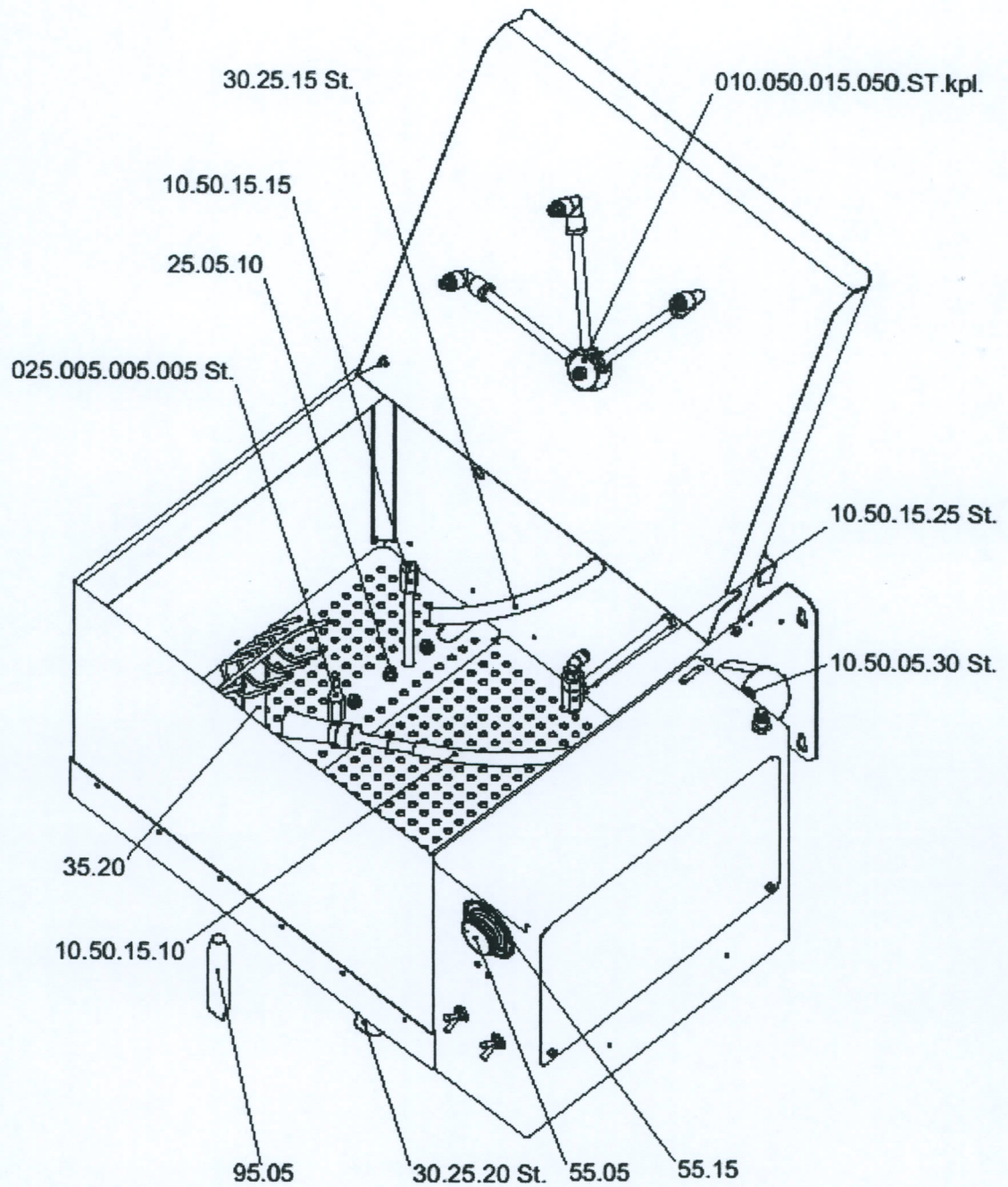

B-TEC Ersatzteil-Bestellnummern

Typ: Starter

Seite 2

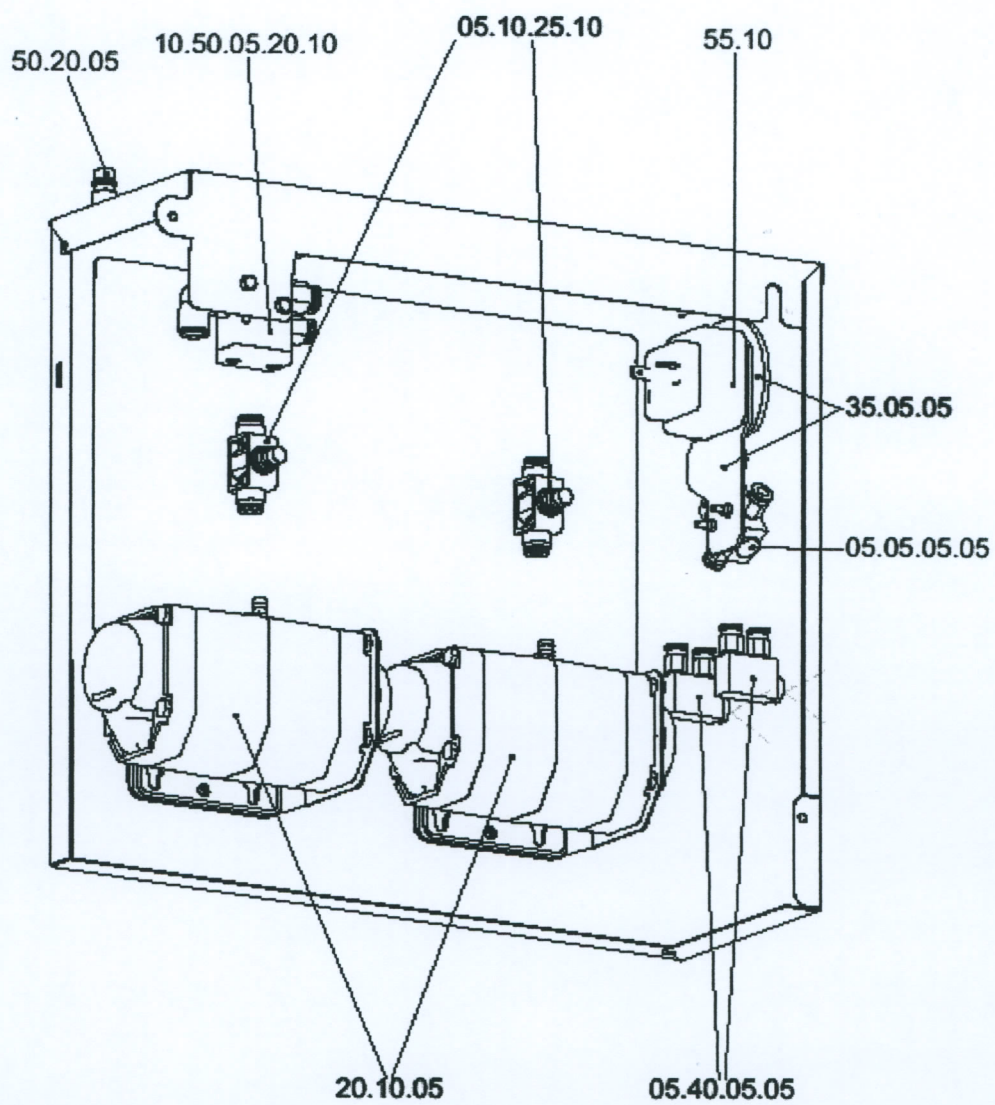

B-TEC Pneumatikplan und Ersatzteil-Bestellnummern

Typ: Starter Seite 3

